

# 360° Compression Tool - RG59 and RG6 Connectors

CTF-180

Manual/Instructions

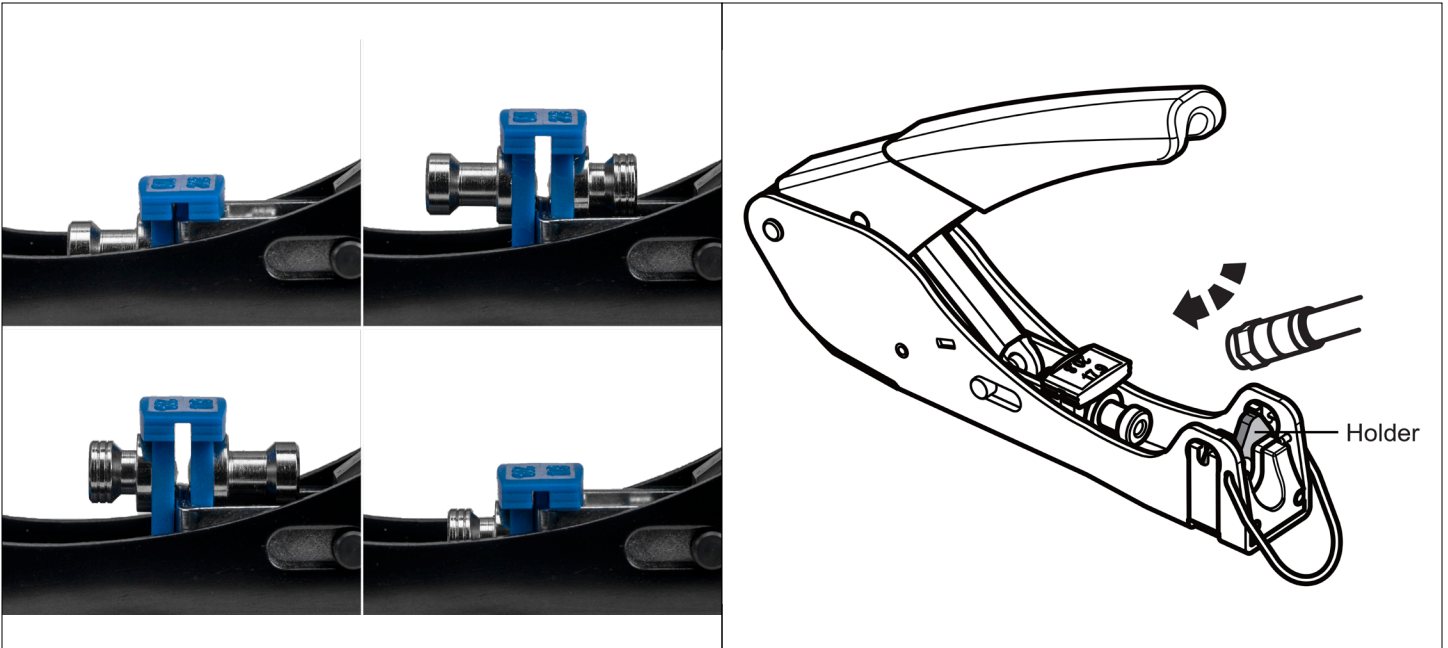

## Instructions:

1. Select the proper plunger length by removing the plunger, rotating plunger to the 17.9 or 20.8mm marking and reinstall the plunger
2. Prep the cable and insert F connector onto cable
3. With the connector pushed properly onto the cable, place the connector into the crimp holder, and squeeze the handles together

### Distribution:



HSO Hertzinger BV  
't Koendert 1  
3831 RB Leusden

+31-334610337  
info@hertzinger.nl  
www.hertzinger.com

**MADE FOR LIFE®**